

Pressure Test System TP1-40



-1 to 40 bar / -30 inHg to 600 psi Pneumatic Pressure and Vacuum



FEATURES

- **Dual source of pneumatic pressure and vacuum.**
- **Fully portable hand operated unit supplied as a complete kit.**
- **Generating up to 40 bar / 600 psi pressure or 96% vacuum.**
- **Adjustable stroke to provide over pressure protection.**
- **Quick fit instruments are available to use with the system including electronic calibrators, digital indicators and analogue gauges.**
- **The TP1- 40 is supplied in a light, high quality carrying case, with adaptors, a set of washers, seals and provision for additional instruments.**

The TP1- 40 Pressure Test System has been introduced to complement an already extensive range of pressure calibration products and can be used for calibration checks on pressure transmitters, pressure switches, indicators, recorders and controllers.

Calibration checks can be carried out simply by temporarily shutting off line pressure, selecting the digital indicator or test gauge required and connecting the instrument via the flexible hose and swivel adaptor to the pressure measuring instrument to be checked. The range of adaptors enables connection to most gauge threads.

TP1- 40 can be used as a portable Pressure Comparator in conjunction with various pressure indicating devices.

This precision unit includes an adjustable over pressure protection system as standard.

www.si-pressure.com

Tel: 0121 784 6855 (UK) Tel: +44 121 784 6855 (Int)
Fax: 0121 784 4795 (UK) Fax: +44 121 784 4795 (Int)



TP1 Specifications

Key:

1. Pressure port - 3/8" BSP Parallel female connection to take master instruments e.g. digital or analogue gauge, PC6 PRO Calibrator (1/4"NPT Female adaptor available).
2. Fine adjustment valve.
3. Pressure release valve.
4. Pressure / Vacuum selector
5. Adjustable stroke for varying maximum pressure output (over pressure protection).
6. BSP or NPT adaptor set
7. Flexible hose to item under test.
8. Nylon seals for BSP adaptors (see seal kit provided)
DO NOT use 'PTFE' tape for sealing with parallel threads
9. Knurled 'quick-fit' connectors
10. Pump Handles

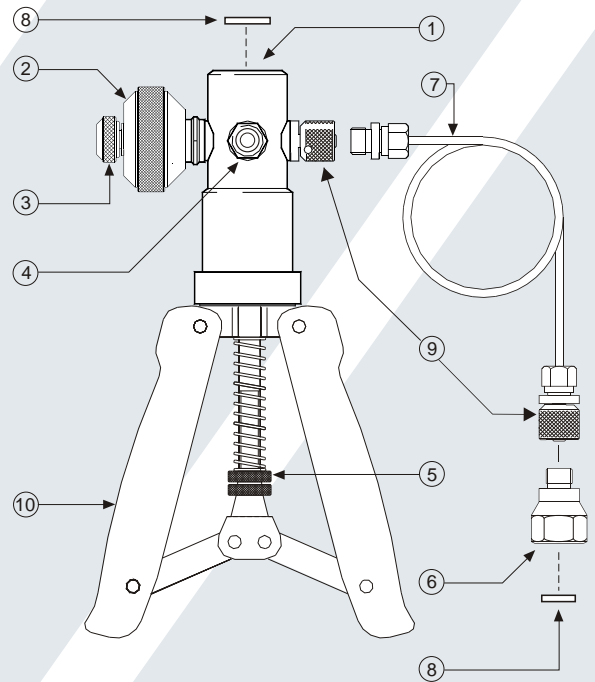

Specification

- Output Pressure:** 0 to 40 bar / 0 to 600 psi (Adjustable)
- Output Vacuum:** 96% (0 to -0.960 bar / 0 to -29 in Hg (Adjustable) at 1000 mbar ambient)
- Materials:** Bright nickel plated brass, clear anodised aluminium, Nylon.
- Adjustment:** Fine volumetric pressure / vacuum adjuster.
- Dimensions:** 220mm (L) x 105mm (W) x 63mm (D).
- Weight:** 650 grams.

Instrument Options:

- Pressure Calibrator (PC6 PRO)
Digital Test Gauge (DTG-2K)
TPG Analogue Gauges

Accuracy FS:

- 0.05%, 0.025%
0.2%
1.0%

Ordering Codes

- | | |
|-------------------------------------|--|
| TP1- 40 | Hand held pressure test system in rigid carrying case with 1 metre flexible hose and adaptor set |
| PC6, PC6-PRO, PC6-IS, PC6-AV | A range of Pressure Calibrators available between -1 and 40 bar / -30 inHg and 600 psi |
| DTG-2K | A range of Digital Indicators up to 30 bar (450psi) |
| TPG range | A range of analogue gauges between -1 and 40 bar / -30 inHg and 600 psi |
| TPK1 | Service kit containing a set of seals. 'O' rings, retaining screws and allen key |
| LTPA-BSP-QF | Set of 7 BSP 'quick-fit' adaptors |
| LTPA-NPT-QF | Set of 6 NPT 'quick-fit' adaptors |



FM 20157



31-0267 Iss.5. DIM.5193